



COMMERCIAL BUS

MIRROR ASSEMBLIES | REAR AND SIDE VIEW CAMERA SYSTEMS
CONTINUOUS & EVENT VIDEO RECORDING CAMERAS
INTEGRATED PRODUCTS | COLLISION AVOIDANCE SYSTEMS
SENSOR SYSTEMS

A SAFER POINT A TO POINT B...

Safety is always a priority when transporting passengers. Rosco vision safety products are designed to meet the requirements of commercial vehicle applications. Our driver assistance products aid operators in maneuvering vehicles around busy urban streets as well as small local roads. Rosco develops customized commercial bus products for safety improvements. Our automotive event recorders deliver distinct advantages, such as immediate driver feedback & keep drivers aware of their actions. Combine data, video and real-time driver feedback to reduce risk throughout your fleet. Let Rosco's best-selling cameras work for you day and night to increase safety & visibility.

Table of Contents

Mirror / Monitors	2
Continuous HD Video Recording	4
Cloud Storage Solution	5
Surround View Camera System	6
Collision Avoidance System	7
Cameras & Monitors	8
Backup Safety Sensors	10
Rearview Mirrors	11
Break Away Arm Assemblies	12
Heavy Duty Fender Mount	13
Combo & Interior Mirrors	14
Control Switches	15

MOR-Vision® Ecosystem



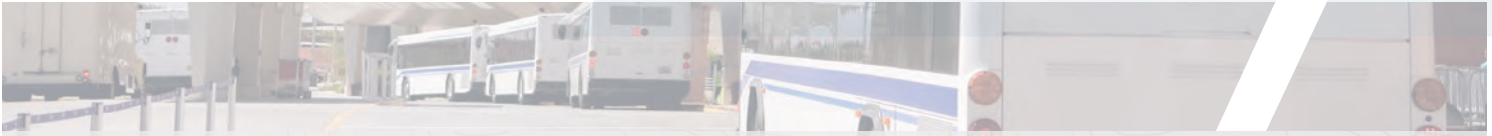

MOR-Vision® Mirror/Monitor Backup Camera Systems

Rosco Vision Systems introduces a revolutionary new backup camera system (STSK8830DX) for medium to large vehicles. This new system utilizes an interior rearview mirror (STSM830DX) to display a 10" LCD monitor when the vehicle is in reverse operation. This monitor allows the driver to see behind the vehicle, and once the vehicle is shifted to all other modes of operation a normal mirror view reappears.

- + Mirror/monitor allows the driver to see the camera image behind the vehicle when in reverse.
- + Normal mirror view reappears once vehicle is shifted out of reverse.
- + LCD color monitor in rearview mirror.
- + Simple rearview mirror install.
- + Optional interior camera view.
- + Two camera inputs with automatic triggers.
- + 150° Diagonal field of vision.
- + One year warranty.

MONITORS

KITS



STSM830D

STSM830DX

WIDER FOV

CONVEX MIRROR WITH 10" MONITOR



STSM530

STSM530

FLAT MIRROR WITH 7" MONITOR

STSM530D

WIDER FOV

CONVEX MIRROR WITH 7" MONITOR



STSM240

STSM240

FLAT MIRROR WITH 4.3" MONITOR



STSM244

STSM244

FLAT MIRROR WITH 7" MONITOR

STSK8830DX

CAMERA: STSC109B
65' HARNESS: STSH341

STSK5530

CAMERA: STSC109B
33' HARNESS: STSH343

STSK5530D

CAMERA: STSC109B
33' HARNESS: STSH343

STSK4642

CAMERA: STSC109B
33' HARNESS: STSH343

STSK4730

CAMERA: STSC130B
33' HARNESS: STSH343

CONTINUOUS HD VIDEO RECORDING



DUAL VISIONTM XC4

Rosco's Dual-VisionTM XC4 has the capacity to identify unsafe driving behavior through its ability to continuously record video and provide instant driver feedback when an event occurs.

PN: DV440
Includes 64GB SD with DV-PRO[®] 5 software
Fleet Database Management System

OPTIONAL ENHANCEMENTS



Continuous HD Video

Continuously monitors and captures driving behavior using HD quality recording while simultaneously providing real-time driver feedback when an event occurs.



SD Card

Fleet manager can remove secured SD card from recorder and view/save continuous video and/or events. Up to 512GB SD card and 1000+ hours capacity.



Audible Chime

Provides instant driver feedback when an event parameter is violated, keeping the driver aware and accountable for their behavior. (can be turned off by fleet management)



CHANNELS

Additional Cameras

Allows for two extra inputs for up to 8 additional camera views anywhere inside or outside of the vehicle for maximum vehicle coverage.



4G
LTE

4G LTE Capability

Allows fleet managers to review and download video events while the vehicle is still on the road. Fleet managers can also access live streaming video.



WI-FI

Wi-Fi Capability

Fleet manager to have cloud based Wi-Fi upload of events and/or continuous video upon vehicle return to base.

//DV-PRO[®]



Four Camera Quad Screen View

Maximize your data's potential with the DV-Pro[®] 5 fleet database management system. This software was developed specifically for organizing information captured by Dual-Vision XC4 recording devices. DV-Pro[®] 5 makes it fast and easy to view or transfer recorded data, locate specific events on footage, archive or discard content, and compile reports or email files. DV-Pro[®] 5 driver tools give greater control of information generated by high capacity Dual-Vision XC4 recorders. You can conduct searches based on detailed criteria and quickly make note of key events such as speed overages.

ROSCOLive™

The RoscoLive™ Cloud Storage feature allows the Dual-Vision XC4 to automatically send snapshots and/or video clips of critical incidents & events according to pre-configured rules set up by the fleet administrator for real-time viewing.



//AUX CAMERAS (OPTIONAL)



The Dual-Vision™ XC4 is capable of recording video from two extra auxiliary 4-pin (AUX) cameras which may be connected to the external camera ports in the PDC module. This extra camera feature can be expanded from two extra cams to eight extra cams with the use of Rosco's STSS1000A splitter for a total of 10 views.



STSS1000A

EXTERIOR CAMERAS



STSC168
HD Side Camera



STSC167
HD Side Camera

INTERIOR CAMERAS



STSC169
HD Interior Dome Camera
BLACK



STSC170
HD Interior Dome Camera
WHITE

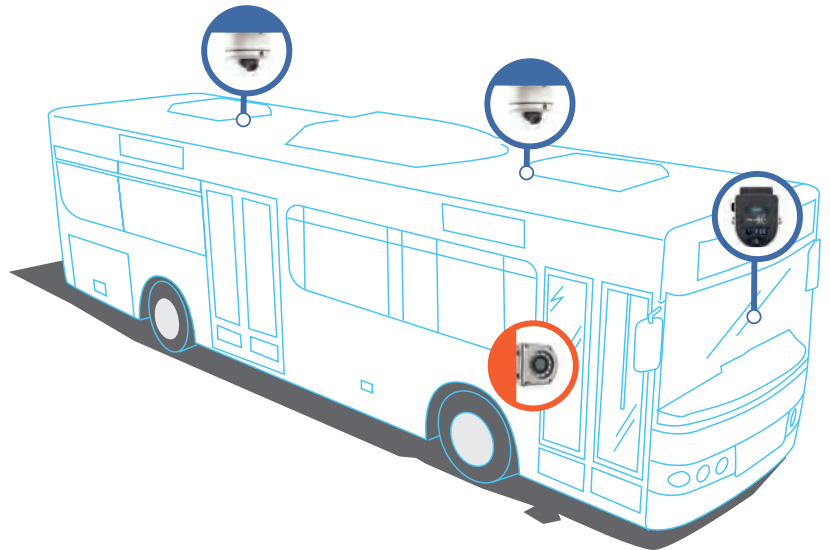

360° SURROUND VIEW CAMERA SYSTEM



Rosco's Safe-T-Scope 360TM has the proven reliability of the Safe-T-Scope[®] Series Cameras with 360° Aerial Coverage of the Vehicle.

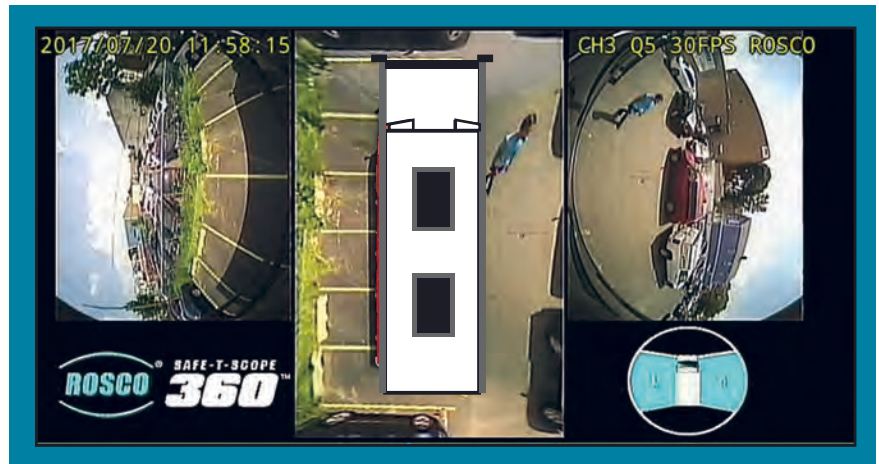

BENEFITS

- + Meets the requirements of FMVSS 111 rear visibility standards.
- + Increase driver awareness.
- + Provide visual coverage of blind zones that are pertinent to large vehicles.
- + Reduce risk of collisions with Vulnerable Road users (VRUs).
- + Provide clear vision on sides of vehicles for narrow roadways.
- + Expanded side vision when reversing into a blind zone.

FEATURES

CAMERAS	(4) 185° Field of View Cameras for optimal coverage around the vehicle.
MONITOR	The Rosco monitor displays a high brightness image of the vehicle and the vehicle's blind spots.
IMAGE STITCHING	The image stitching capability of the Safe-T-Scope 360 TM system provides a 360° perimeter view around vehicle.
IMAGE VIEWS	The Safe-T-Scope 360 TM allows for multiple views to enhance points of focus during vehicle operation. (ie: Vehicle rear in reverse)

CAMERAS

CONTROL BOX

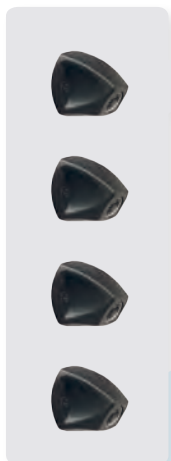

Monitor Options



STSM254
7" LCD MONITOR

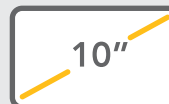

STSM830DX
w/ 10" LCD MONITOR

COLLISION AVOIDANCE SYSTEM



MOBILEYE SHIELD +

This is an example of one turn of likely thousands this bus will make over the course of a week. Smart vision cameras on the front and sides of the bus track possible collision courses and alert the driver in time to avoid or lessen incident severity.



The Mobileye® Shield+ System is the most effective technological advancement for preventing collisions between vehicles and Vulnerable Road Users (VRUs) including pedestrians and cyclists.

VRUs often are not seen by the bus operator due to large blind spots around the vehicle, especially when making turns. Bus operating conditions demand the highest level of awareness by the vehicle operator. Shield+ increases awareness and safety for the driver and VRUs around the bus to prevent collisions.

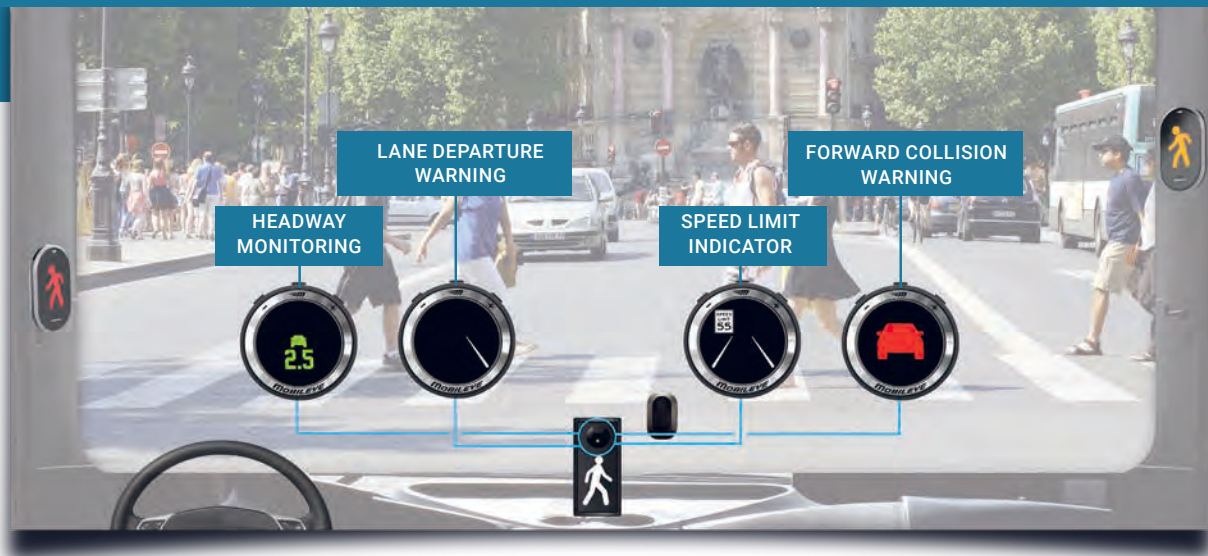

1-800-227-2095
www.Rosco-adas.com

ROSCOVISION.COM | ROSCOMIRRORS.COM
INFO@ROSCOVISION.COM

90-21 144TH PLACE
JAMAICA NEW YORK 11435



Visit www.RoscoVision.com

We cover all the safety angles so your vehicle can backup safely. Replace a standard rearview mirror with one of our MOR-Vision mirror/monitors that displays an LCD image as soon as the vehicle is shifted into reverse. Or install a Rearview Mirror Backup Camera that delivers an unobstructed view of what's behind the vehicle even when it's dark outside. Reduce the risks of moving in reverse & give drivers the tools to maneuver easily in reverse with one of our backup camera kits.



License Plate Camera
STSC112



Ford Sprinter Brake Light Camera
STSC149A
*Other OEM Specific Brake Light Cameras Available



Bullet Camera
STSC106



HD Interior Dome Camera
STSC169



Side Camera
STSC132W
STSC133W



Rear Look Down Camera
STSC141



Rear Look Down or Side Mount Camera
STSC111B

SAFE-T-SCOPE®

Stand Alone Monitors

Rosco offers an array of monitor types and sizes to fit your vehicle and application. We also offer different mounting options that are easily installed on the dashboard, windshield or overhead. Rosco's heavy duty monitors include multi-input and split view options and weatherproof monitors for open-cab applications. The STSS1000A Splitter Box is compatible with most Rosco monitors allowing a 1-channel monitor to output as a 4-channel screen. Give your drivers the confidence they need to backup safely with a Rosco backup camera and monitor.



// 5" LCD // 7" LCD // SINGLE TO QUAD SCREEN BACK-LIT LCD // ULTRA BRIGHT MIRROR-MONITORS

5 INCH



STSM206
640x480
4:3



STSM208
16:9



STSM243
480x272
16:9

7 INCH



STSM205
800x480
16:9



STSM251
800x480
16:9

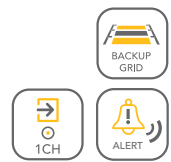

STSM254
800x480
16:9

SPLIT



STSM270
800x480
16:9



STSM207
800 x 480
16:9



STSS1000A
Convert 1,2 or 3 Channel Input
Monitors to 4 Channel Quad Views

BACKUP SAFETY SENSORS

Backup Safety Sensors

Rosco backup sensor kit alerts drivers to unsafe situations behind a vehicle. Rosco designs flush mount and under-the-bumper backup sensors for a range of applications. Commercial vehicle backup sensors give drivers the information they need for safe reversing.

Look to Rosco backup sensors for transit buses and other large vehicles. With sensor kits and backup cameras, we deliver rugged tools for safe driving.

WIRELESS



BSSK1000

Ultrasonic wireless undermount sensor kit.



BSSK1001

Ultrasonic wireless flush mount configuration.

HARD WIRED



BSSK4000

Heavy duty ultrasonic system with (4) bumpers and (2) roof mount sensors.



BSSK4006

Heavy duty ultrasonic system with (8) sensors and (8) separate bumper mounts.

//ACCUSTYLE® 815 SERIES 8" X 15" DUAL MIRRORS

FEATURES AND BENEFITS

- + Lightweight and built rigid for minimal vibration.
- + Certified by OEM's to meet FMVSS 111 requirements.
- + Same model can be mounted as upright, overhang or two point mount.
- + Reduces inventory of replacement parts.
- + Aerodynamic, wind tunnel tested profile has lower drag coefficient for increased fuel economy.
- + Used on all commercial bus types including cutaway, conventional and transit style.
- + Available heated, motorized, embedded or external turn signal LED's, chrome.
- + Each motorized mirror lens is four way adjustable.
- + Hidden wire and connectors.
- + Full height rear entry cap allows for simple installation and ease of maintenance including access to wires and harnesses.

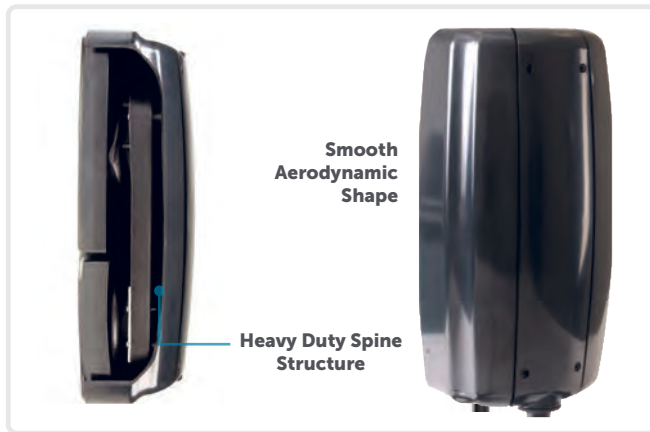

PART NO.	DESCRIPTION
815	8" X 15" DUAL MIRROR, TWO POINT MOUNT, MOTORIZED, 12 VOLT
8150G	8" X 15" DUAL MIRROR, OVERHANG MOUNT, MOTORIZED, 12 VOLT
815SLU OR 815SRU	8" X 15" DUAL MIRROR, UPRIGHT MOUNT, MOTORIZED, 12 VOLT WITH L OR R SIGNAL LENS LEDS
815SLEU OR 815SREU	8" X 15" DUAL MIRROR, UPRIGHT MOUNT, MOTORIZED, 12 VOLT WITH EXTERIOR L OR R SIGNAL LEDS
815U	8" X 15" DUAL MIRROR, UPRIGHT MOUNT, MOTORIZED, 12 VOLT
M815	8" X 15" DUAL MIRROR, TWO POINT MOUNT, HAND ADJUSTABLE
M8150G	8" X 15" DUAL MIRROR, OVERHANG MOUNT, HAND ADJUSTABLE
M815U	8" X 15" DUAL MIRROR, UPRIGHT, HAND ADJUSTABLE

**ADD SUFFIX "H" FOR HEATED OPTION

ACCUSTYLE® OPTIONS



**EXTERNAL
TURN SIGNAL LED**



**INTEGRATED TURN
SIGNAL LED**



**REAR LOOKING
CAMERA**

BREAKAWAY ARM ASSEMBLIES

//SWIVEL & SPRING-BREAK® DETENT

Non-Detent Swivel Arm Assembly

Rosco's Non-Detent Swivel Arm Assembly is the industry standard. Its unique sandwich design provides unparalleled mirror assembly adjustment while being powerful enough to hold positions at highway speeds. With infinite adjustability, the vehicle operator can locate the mirror arm and head to an optimal location for each distinctive driver eye-point location.

NON-DETENT SWIVEL ARM ASSEMBLY



Optional Stainless Steel Finish Available

ADJUSTABLE BY HAND YET POWERFUL ENOUGH TO HOLD POSITIONS AT HIGHWAY SPEEDS

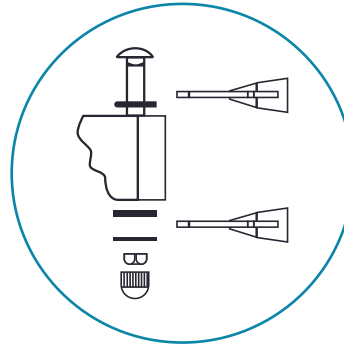

SWIVEL

UNIQUE HINGE DESIGN ALLOWS FOR WIDE RANGE OF SWINGING MOTION ALLOWING DRIVERS TO ADJUST THE POSITION OF ARMS AS WELL AS MIRRORS TO FIND THE OPTIMAL VIEW FROM THE DRIVER'S SEAT.

Spring-Break® Detent

This line of mounting arms has a unique Spring Loaded Detent mechanism that dampens vibration and keeps the arm locked in position. Heavy-duty cast aluminum mount and swivel provide long lasting reliability and unequaled stability. Tubular construction keeps things economical. Totally maintenance free and offered for Ford, GM, Freightliner and Navistar cutaway buses.

SPRING-BREAK® MOUNT

Tubular construction for strength, custom length and hidden wiring.

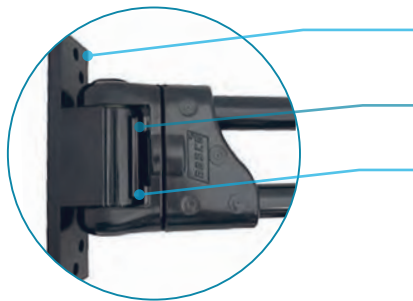

VARIETY OF MOUNTING BASES AND HOLE CONFIGURATIONS

HIDDEN INTERNAL SPRING DETENT MECHANISM

MULTIPLE CUSTOM GROOVE LOCATIONS FOR VARIABLE DETENT ANGLES

//CUSTOM OPTIONS AVAILABLE ON THESE CHASSIS

- + Ford 350/450 E-Series
- + Ford 550/650 F-Series
- + Ford Transit
- + Chevy 3500
- + Navistar
- + Freightliner



FORD TRANSIT REARVIEW MIRROR MOUNT

HEAVY DUTY FENDER MOUNT

//E-Z BRACKET®

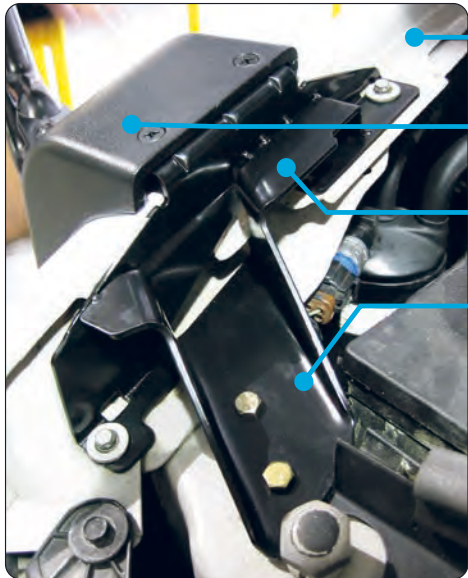

HD E-Z Bracket® Installation

Fender
Cast Aluminum Mounting Base
E-Z Bracket®
HD Bracket

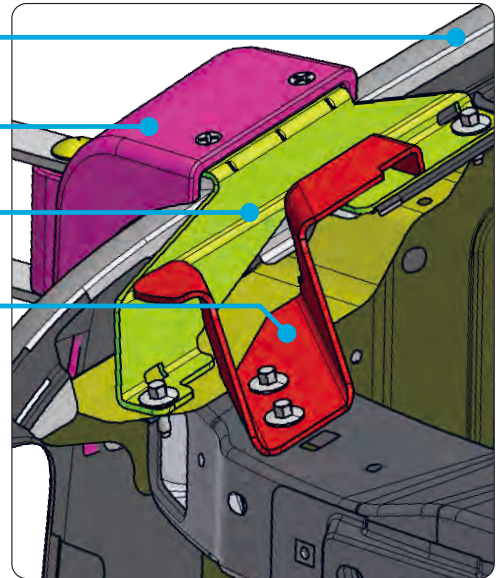

HD E-Z Bracket® Model

FEATURES AND BENEFITS

- + Rosco's unique ferrule system transfers the strength of the inner heavy-gauge fender wall to the exterior of the vehicle.
- + Installation is completed with two holes instead of as many as twelve.
- + Eliminates the large arms and braces commonly used on passenger side mirror.
- + Robust cast aluminum mounting base provides a stable mount for vibration resistance and durability.
- + Low-profile construction is aerodynamic and aesthetically appealing.
- + Contoured profile matches the fender perfectly for a solid mount that looks great on the vehicle.
- + Available for both Ford and GM vehicles.
- + Vibration reduction / dual wall tube.

//DUAL-WALL TUBING

Dual-Wall Arms have the added strength where it is needed most at the mounting location, but the benefit of thinner wall, light weight performance through the majority of the arm. When coupling all three of Rosco's fender mount weapons... the Dual-Wall Arm, the HD E-Z Bracket®, and the AccuStyle® lightweight mirror head, the Rosco Mirror "System" has never been stronger in overcoming the many challenges of light weight fenders.

Patented E-Z Bracket® System

Rosco's patented E-Z Bracket® System makes installation of a Type "A" bus mirror system easier than ever before. (Patent No. 7,055,973). The under-the-hood mount utilizes existing fender mounting bolts to secure the mount below the hood.

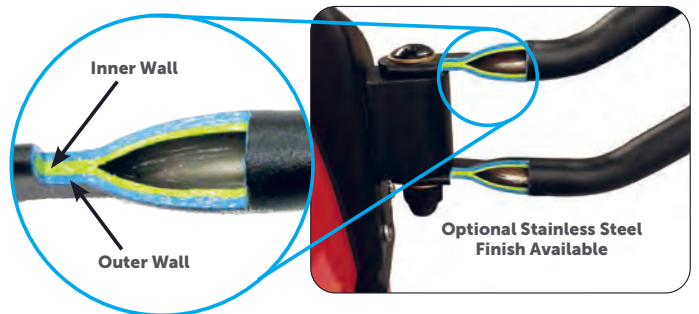

Dual-Wall Tube Detail

Fender Mounted E-Z Bracket® with Dual-Wall Tubing for Extra Stability

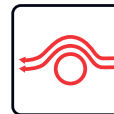

AERO DYNAMIC



DUAL WALL TUBE



VIBRATION REDUCTION



2-HOLE INSTALLATION

COMBO & INTERIOR MIRRORS



AccuStyle® Rearview & Eye-Max® LP Crossview Combination Assembly

Interior Mirrors

- + All models manufactured with safety glass.
- + Padded edges meet federal and state requirements for safety.
- + Available with non-glare glass.
- + Many come complete with mounting brackets.
- + Powder coated for durability.
- + Available in various sizes and mounting configurations.



362R 12" ROUND CONVEX MIRROR W/ BALL STUD MOUNT



530 6" X 16" INTERIOR MIRROR



830D 8 X 15 INTERIOR MIRROR, CONVEX



609DRYL 6" X 9" ENTRANCE DOOR CONVEX MIRROR W/ 616INT/BKT



616DRYL 7" X 16" ENTRANCE DOOR CONVEX MIRROR W/ 616INT/BKT

PART NO.	DESCRIPTION
530	6" X 16" INTERIOR MIRROR
830D	8 X 15 INTERIOR MIRROR, CONVEX
416	4" X 16" INTERIOR MIRROR
609D	6" X 9" ENTRANCE DOOR CONVEX MIRROR
609DRYL	6" X 9" ENTRANCE DOOR CONVEX MIRROR W/ 616INT/BKT
616DRYL	7" X 16" ENTRANCE DOOR CONVEX MIRROR W/ 616INT/BKT
355N/355S/355V	6" ROUND FLAT MIRROR W/ MOUNTING BRACKET
362R	12" ROUND CONVEX MIRROR W/ BALL STUD MOUNT
601D	6" ROUND CONVEX MIRROR W/ CENTER BALL STUD
710	7" X 10" CONVEX MIRROR

Combination Assemblies

More than one Rosco fender mounted mirror can benefit from the uniquely stable E-Z Bracket® HD mounting base. The "Combo" fender mounted mirror design allows both Rearview and Front Crossview Mirrors to efficiently install on a common point, thus minimizing holes in the vehicle and maximizing ease of installation, and performance.

Mirror Control Switches

A variety of switches, including heater controls and timers, are available to suit all requirements. Wire harnesses are available from stock or in custom lengths, with many different standard and weatherproof connectors.



HAR5020

Heater control switches available in toggle or momentary functionality with optional heater shut-off timer.



HAR5012 (H/R/LED) or HAR5013 (H/R)

Remote control knob style switches available with or without illumination.



SWI1010 - VERTICAL

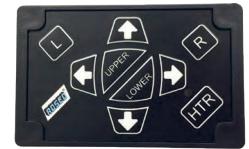

SWI1011 - HORIZONTAL

Illuminated membrane switches with combination heater and remote control functions for up to four lenses.

Rosco's family of remote control/heater membrane switches consolidates the function of two "knob" style remote switches and a separate heater switch into a small solid state package with illumination, circuit protection and unmatched durability.

Switches and Components

PART NO.	DESCRIPTION
HAR5003	2X SW-3 ROUND REMOTE SWITCHES FOR REMOTE ONLY
HAR5004	2X SW-3 ROUND REMOTE SWITCHES & 1X SW5-HT HTR SWITCH w/ TIMER
HAR5020	2X SW-3 REMOTE SWITCHES & 1X SWI2005 HTR SWITCH IN FORD E-SERIES DOOR POD
HAR5029	2X SW-3 ROUND REMOTE SWITCHES & 1X SWI2005 HTR SWITCH w/ TIMER IN FORD E-SERIES DOOR POD
HAR5032	2X SW-3 ROUND REMOTE SWITCHES & 1X SWI2005 HTR SWITCH w/ TIMER, 10-PIN FOR LED IN FORD E-SERIES DOOR POD
HAR5012	SWITCH PLATE ASSEMBLY, 2 REMOTE SWITCHES AND 1 MOMENTARY HEATER W/ 10 MINUTE HEATER TIMER RELAY, W/ 10 PIN CONNECTORS FOR LED TURN SIGNAL
HAR5013	SWITCH PLATE ASSEMBLY, 2 REMOTE SWITCHES AND 1 MOMENTARY HEATER W/ 10 MINUTE HEATER TIMER RELAY
SWI1010	INTEGRATED MEMBRANE SWITCH w/ HTR TIMER FOR REMOTE & HTD / REMOTE, VERTICAL CONFIG
SWI1011	INTEGRATED MEMBRANE SWITCH w/ HTR TIMER FOR REMOTE & HTD / REMOTE, HORIZ CONFIG
SWI1013	INTEGRATED MEMBRANE SWITCH w/ HTR TIMER FOR REMOTE / LED & HTD / REMOTE / LED, VERTICAL CONFIG
SWI1014	INTEGRATED MEMBRANE SWITCH w/ HTR TIMER FOR REMOTE / LED & HTD / REMOTE / LED, HORIZ CONFIG

NEW YORK SINCE 1907



Rosco was established in 1907. For over a century, our goals have remained the same: We are committed to producing the highest quality automotive products and providing the level of service our customers have grown to expect.

Today, we supply our products to every commercial bus and school bus manufacturer in North America. Our products are designed and built in the USA. Our staff has grown to over 300 people in facilities totaling over 150,000 square feet.

As we move forward we have set our goals even higher. We are now certified to ISO-9001:2015. Our focus on Total Quality Management and continuous improvement will keep our product quality at levels our customers demand.

We will strive to improve our customer service through online and other electronic resources. We will continue to develop newer and better products to serve the ever-changing needs of the marketplace of tomorrow.



90-21 144TH PLACE, JAMAICA, NEW YORK 11435
P: 1.800.227-2095 | F: 718.297.0323
INFO@ROSCOMIRRORS.COM
WWW.ROSCOVISION.COM | WWW.ROSCOMIRRORS.COM